

# 1-2 Pallet Handlers

## Models DS-DK



Multiple Pallet Handler are used in all industries characterized by heavy handling of palletized loads and in particular soft drink industries, breweries, mineral water bottling plants, food industries, brick industries.

The Bolzoni Auramo 1-2 Pallet Handlers allow the handling of more loads in less time, increasing productivity and reducing handling costs during storage or loading and unloading of vehicles.

Superior visibility on fork tips across and above the chassis, allows fast, safe and damage-free handling.

Design with optimized number of high quality components and easy and fast replacement of parts subject to wear mean a reduction in service costs.

Thanks to the specific features and to a wide range of capacities and fork openings, the Bolzoni Auramo 1-2 Pallet Handlers offer great flexibility of use and applications and represent a reliable and efficient solution to today's most demanding handling needs.

### Features:

- Dual mounting for high flexibility in rental business as well as high availability for most required forklift capacities in mounting class II and III.
- Frame with small side vertical plates and reduced height from ground level for better visibility from the driver seat and safer operation.
- Profile guided system.
- Innovative and patented sliding arms design.
- Synchronized fork movement with flow divider valve.
- Gas strut in protected central position optimize the inner forks sliding.
- Forks with specially reinforced heel area for longer lifetime, greater strength and higher safety.



# 1-2 Pallet Handlers, Profile Type

## Models DS-DK (Sideshifting)

**Range:** 4,800 - 5,500 Lbs.

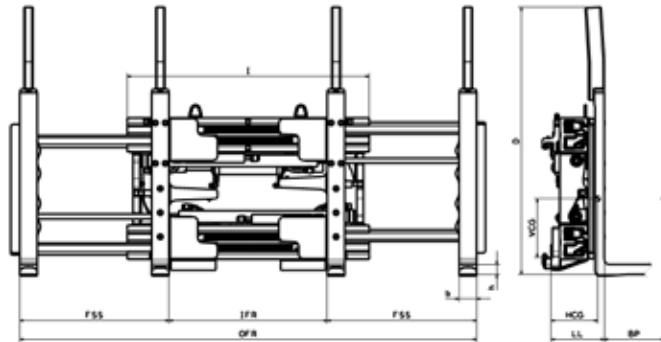

### Features:

- Single/double pallet handler for handling one or two pallets.
- These models offer the possibility to lift pallets on both sides, either singly or two at a time.
- Highest visibility available from the driver's seat.
- Separate sideshift provides constant sideshift range regardless of the fork opening.
- Synchronized fork movement with flow divider valve.
- Gas-strut operated inner fork positioning.
- Incorporated load backrests.
- Self-lubricating polyamide sideshift bearing pads.
- Dual drilled for class II or class III mounting.

Model	Capacity Lbs. @ 24"	Fork Set Spread	Outer Fork Range	Inner Fork Range	Fork Dimensions	Frame Width	Minimum Carriage Width	Height	Weight Lbs.	Horizontal Center of Gravity	Vertical Center of Gravity	Effective Thickness	Mounting Class
	Q	FSS	OFR	IFR	L x b x h ①	I	FL	D	W	HCG	VCG	LL	
<b>Beverage 36" x 36"</b>													
DS 25 DKA-B	5,500	24"	26.0"	80.3"	13.0" 32.3"	36" x 3.2" x 1.8" -1.6"	43.3"	48"	1,311	7.2"	9.7"	9.6"	II
DS 25 DKB-B	5,500	24"	26.0"	80.3"	13.0" 32.3"	36" x 3.2" x 1.8" -1.6"	43.3"	48"	1,302	7.1"	11.3"	9.5"	III
<b>GMA &amp; Chep Block 40" x 48"</b>													
DS 22 DKA-G	4,800	26,8	27.6"	81.9"	14.8" 28.3"	42" X 3.2" X 1.6" - 1.4"	43.3"	48"	1,338	7.5"	9.6"	9.5"	II
DS 22 DKB-G	4,800	26,8	27.6"	81.9"	14.8" 28.3"	42" X 3.2" X 1.6" - 1.4"	43.3"	48"	1,329	7.4"	11.2"	9.0"	III
DS 25 DKA-G	5,500	26,8	27.6"	81.9"	14.8" 28.3"	42" x 3.2" x 1.8" -1.6"	43.3"	48"	1,377	7.9"	9.5"	9.6"	II
DS 25 DKB-G	5,500	26,8	27.6"	81.9"	14.8" 28.3"	42" x 3.2" x 1.8" -1.6"	43.3"	48"	1,368	7.8"	11.0"	9.3"	III
<b>Container 44" x 56"</b>													
DS 25 DKA-C	5,500	24"	26.0"	80.3"	13.0" 32.3"	54" x 3.2" x 1.8" -1.6"	43.3"	48"	1,404	9.9"	8.9"	9.6"	II
DS 25 DKB-C	5,500	24"	26.0"	80.3"	13.0" 32.3"	54" x 3.2" x 1.8" -1.6"	43.3"	48"	1,395	9.7"	10.4"	9.3"	III

### Notes:

- Two hydraulic functions required.
- Total sideshift 8".
- Mountings: Standard ITA mounting. For special mountings, consult Bolzoni Auramo.
- Attention: These attachment models are designed for load handling on forks only. Not suitable for clamping.
- ① 1.8" outer forks - 1.6" inner forks (5,500# cap.)  
1.6" outer forks - 1.4" inner forks (4,800# cap.)

### Options:

- Opening range: special widths and fork opening ranges.
- Non-standard fork lengths and sections.
- Other load backrest heights.



**BOLZONI AURAMO INC.**  
17635 HOFFMAN WAY - HOMEWOOD, ILLINOIS 60430 - USA - Tel. 800-358-5438 - Fax 708-957-8832

[us.bolzonigroup.com](http://us.bolzonigroup.com)  
[sales.us@bolzoni-auramo.com](mailto:sales.us@bolzoni-auramo.com)

**BOLZONI AURAMO CANADA LTD.**  
90C BRUNSWICK BLVD DOLLARD-DES-ORMEAUX, QUEBEC H9B 2C5 CANADA  
Tel. 800-685-7871 - Fax 514-685-5238

[www.bolzonigroup.com](http://www.bolzonigroup.com)  
[sales.ca@bolzoni-auramo.com](mailto:sales.ca@bolzoni-auramo.com)

