

Paper Roll Clamps, 180-degree Rotation

Models ARC-100

Range: 8,500 - 11,800 Lbs.

- 180-degree rotation. Hydraulic cushioning in the vertical end positions.
- Rotating paper roll clamp for safe and effective vertical and horizontal roll handling.
- Slim and smooth arm and frame design, optimal visibility and advanced hydraulic operation.
- Pivoting arm movement. Short and long arms. Non-split long arm for single roll handling. Split arm for 1 - 2 roll handling.
- All hydraulic functions protected with built-in pressure relief valves and check valves. All service and maintenance points easily available.

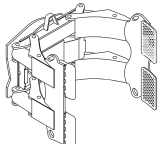
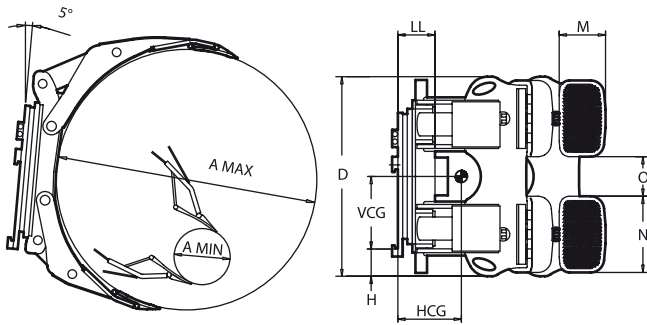

Unsplit long arm

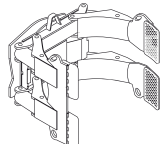

Split long arm

| Model | Capacity Lbs. | Load Center | Roll Range | Height | Weight Lbs. | Horizontal Center of Gravity | Vertical Center of Gravity | Effective Thickness | Contact Pads | Contact Pad Gap | Mounting Height | Mounting Class |
|--|---------------|-------------|------------|--------|-------------|------------------------------|----------------------------|---------------------|--------------|-----------------|-----------------|----------------|
| | Q | BP | A | D | W | HCG | VCG | LL | M x N | O | H | |
| Single roll clamps - Unsplit long arm | | | | | | | | | | | | |
| ARC-100-1651-P | 11,800 | 25.5" | 16"-51" | 40.9" | 2,620 | 11.6" | 15.6" | 8.3" | 11.0"x15.7" | 7.9" | 4.3" | IV |
| ARC-100-1655-P | 10,900 | 27.5" | 16"-55" | 40.9" | 2,650 | 12.0" | 15.6" | 8.3" | 11.0"x15.7" | 7.9" | 4.3" | IV |
| ARC-100-1660-P | 10,000 | 30.0" | 16"-60" | 40.9" | 2,710 | 12.6" | 15.6" | 8.3" | 11.0"x15.7" | 7.9" | 4.3" | IV |
| ARC-100-1663-P | 9,700 | 31.5" | 16"-63" | 40.9" | 2,730 | 13.0" | 15.6" | 8.3" | 11.0"x15.7" | 7.9" | 4.3" | IV |
| ARC-100-1672-P | 8,500 | 36.0" | 16"-72" | 40.9" | 2,920 | 14.4" | 15.6" | 8.3" | 11.0"x15.7" | 7.9" | 4.3" | IV |
| 1 - 2 roll clamps - Split long arm | | | | | | | | | | | | |
| ARC-100-1651-PS | 11,800 | 25.5" | 16"-51" | 40.9" | 2,590 | 11.2" | 15.6" | 8.3" | 11.0"x15.7" | 7.9" | 4.3" | IV |
| ARC-100-1655-PS | 10,900 | 27.5" | 16"-55" | 40.9" | 2,620 | 11.6" | 15.6" | 8.3" | 11.0"x15.7" | 7.9" | 4.3" | IV |
| ARC-100-1660-PS | 10,000 | 30.0" | 16"-60" | 40.9" | 2,680 | 12.2" | 15.6" | 8.3" | 11.0"x15.7" | 7.9" | 4.3" | IV |
| ARC-100-1663-PS | 9,700 | 31.5" | 16"-63" | 40.9" | 2,700 | 12.6" | 15.6" | 8.3" | 11.0"x15.7" | 7.9" | 4.3" | IV |
| ARC-100-1672-PS | 8,500 | 36.0" | 16"-72" | 40.9" | 2,890 | 14.0" | 15.6" | 8.3" | 11.0"x15.7" | 7.9" | 4.3" | IV |

Notes:

- All models with hydraulically positionable short arm.
- Two hydraulic functions required.
- See hydraulic specifications page for pressure and flow rate recommendations.
- Standard contact pads: cast pad with high-friction surface.
- Minimum 5-degree forward tilt on lift mast is required for horizontal handling.
- For 0-degree tilt, special arms are available. Consult Bolzoni.

Options:

- Special roll ranges.
- Fixed (non-moving) short arm.
- Contact pad options:
 - steel-sprayed
 - rubber faced
 - polyurethane faced
 - full length contact pads.

