

# Paper Roll Clamps

## Models LA-4

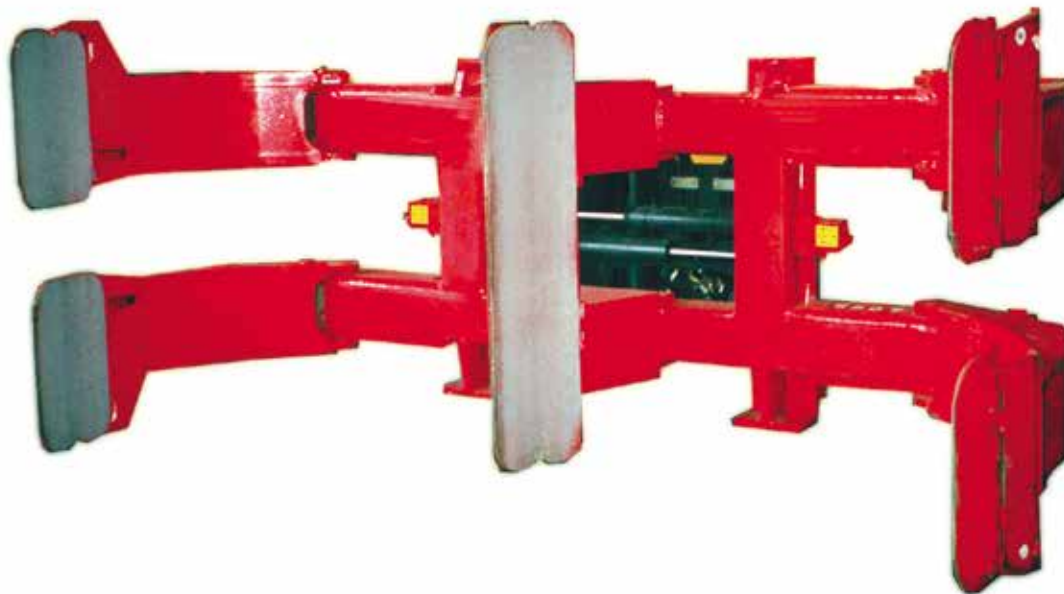

The Bolzoni Auramo LA-4 model paper roll clamps are designed for high volume paper handling in paper mills, harbors, paper warehouses and transport companies.

The clamps are designed for vertical handling of 2 - 4 paper rolls. Several model sizes available with a wide capacity and roll range choice.

Depending on the chosen model, the clamps are able to handle paper rolls from 11,000 up to 22,050 Lbs, with maximum paper roll diameter from 2 x 51" up to 2 x 71".

Pivoting arm movement, with short and long arms provides wide roll range. Twin arm pairs enable the handling of two rolls side-by-side. Fixed short center arm.

Long arms are split to enable safe and non-damaging handling of two paper rolls on top of each other.

Several contact pad options available.



**Range:** 11,000 - 22,050 Lbs.

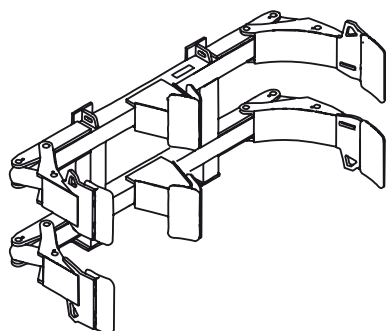
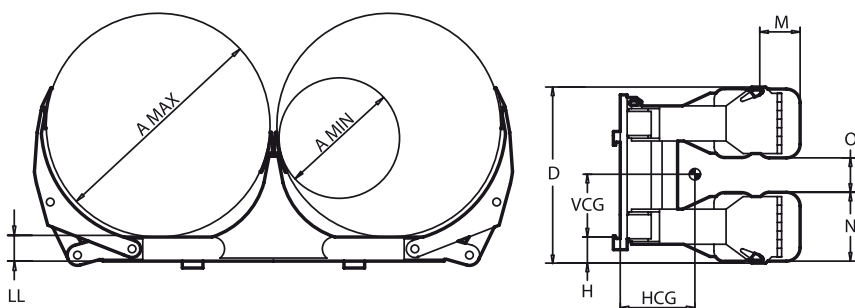

- Multiple Paper Roll clamp for vertical handling of 2-4 rolls at a time.
- Pivoting arm movement, equal length split long arms, fixed center arm. Several arm and contact pad options in standard series.
- Thin-arm profile ensures tight stacking with excellent visibility, and damage-free handling.
- Strong light body, with favorable effective thickness, maximizes the residual capacity of the truck.

Model	Capacity Lbs.	Load Center	Roll Range	Height	Weight Lbs.	Horizontal Center of Gravity	Vertical Center of Gravity	Effective Thickness	Contact Pads	Contact Pad Gap	Mounting Height	Mounting Class
	Q	BP	A	D	W	HCG	VCG	LL	M x N	O	H	
LA-500N-4	11,000	26"	2x[10"-51"]	40.9"	1,910	13.0"	16.1"	6.3"	9.4"x15.7"	7.9"	①	IV
LA-600N-4	13,200	26"	2x[10"-51"]	40.9"	2,370	13.0"	16.1"	7.1"	9.4"x15.7"	7.9"	①	IV
LA-800N-4	17,600	31"	2x[35"-63"]	48.8"	2,840	13.8"	21.5"	7.1"	11.0"x19.7"	7.9"	①	②
LA-840N-4	18,500	30"	2x[35"-59"]	48.8"	2,820	13.6"	21.5"	7.1"	11.0"x19.7"	7.9"	①	②
LA-860N-4	18,950	28"	2x[35"-55"]	48.8"	2,800	13.4"	21.5"	7.1"	11.0"x19.7"	7.9"	①	②
LA-900N-4	19,800	26"	2x[35"-51"]	48.8"	2,750	13.0"	21.5"	7.1"	11.0"x19.7"	7.9"	①	②
LA-1000-4	22,050	35"	2x[39"-71"]	48.8"	3,390	13.8"	21.5"	7.1"	11.0"x19.7"	7.9"	①	②
LA-1000S-4	22,050	27"	2x[26"-53"]	48.8"	2,910	13.4"	21.5"	7.1"	11.0"x19.7"	7.9"	①	②

### Notes:

- One hydraulic function required.
- Consult Bolzoni Auram for hydraulic pressure and flow rate recommendations.
- Standard contact pads: cast pad with high-friction surface.
  - ① Consult Bolzoni Auramo.
  - ② Special mounting required.

### Options:

- Special roll ranges.
- Separate sideshift.
- Independent arm movement.
- Contact pad options:
  - steel-sprayed
  - polyurethane-faced
  - rubber faced
  - flexible.

Hydraulically adjustable frame width.

- Easy clamp width adjustment to varying paper roll diameter ranges.

