

Paper Roll Clamps

Series AMC

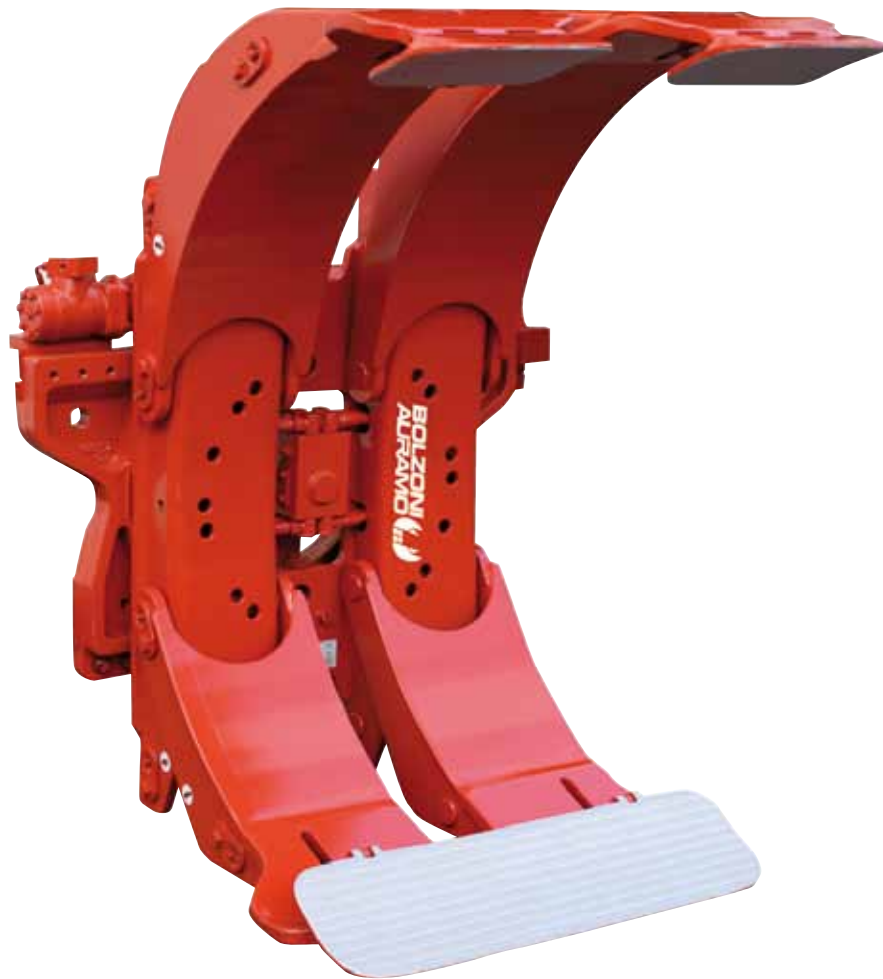

360 degree continuous rotation

Series AMC 360 degree continuous rotation paper roll clamps are designed for horizontal and vertical paper roll handling in a large range of diameters.

Thanks to the wide range of capacities and openings, these clamps are suitable in a variety of applications in paper mills, ports, warehouses and printing companies.

Series AMC paper roll clamps have dedicated models available for single roll handling as well as for multiple roll handling. Pivoting long arm movement allows a wide roll diameter range handling with minimized overall unit dimensions.

Thin profile of contact pads and arms prevent roll damage and allow narrow stacking.

360 degree continuous rotation through direct worm/ring gear drive and clutch brake system for more precise positioning and faster handling.

Compact and efficient design for high residual capacity.

Service friendly hydraulic rotating centre for easy maintenance and low repair cost.

Various pad covering available for every type of paper and application.

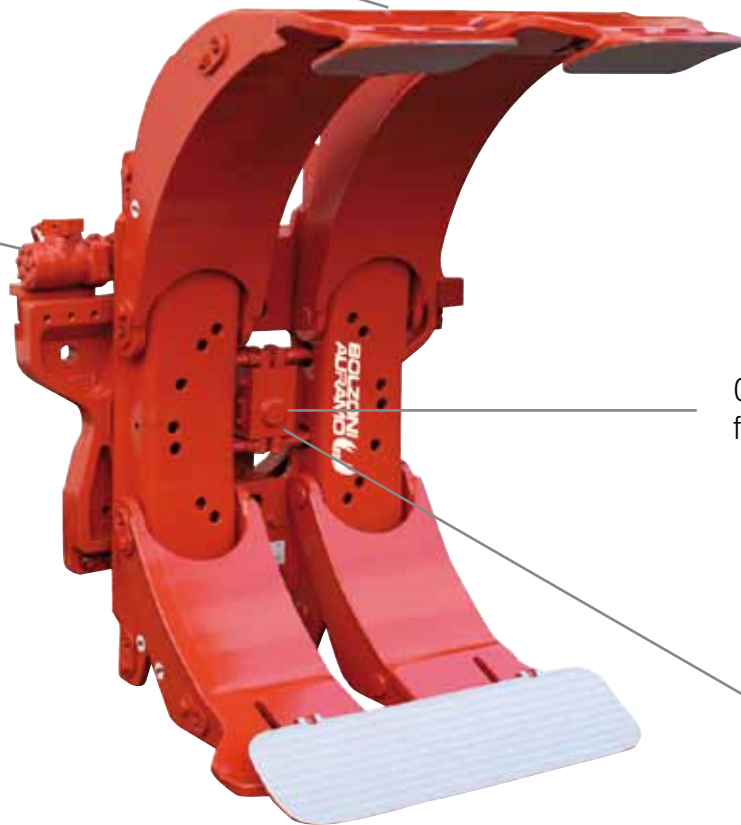



The direct drive

Direct drive without transmission with only 2 components involved in the power train (hardened and polish steel worn, cast bronze ring gear):

- smooth and precise rotation
- higher number of overlapping teeth
- excellent operational visibility
- high residual capacity.



Advantages only

Front mounting and demounting of symmetrical ring gear:

- easy inspection & maintenance
- longer life
- side grease facility with easy access
- hermetically sealed.

Sensitive and safe operation:

- 2 components direct drive for exact positioning of paper rolls
- Oil motor with hydraulic brake for highest operation safety.



Safe handling

Cylinders with cartridge check valves and test connection.



Damage free handling

Slim design for tight and damage free stacking.

Loaded with options

Mounting

The standard mounting for all series AMC roll clamps is an ITA hook-type mounting. Standard mounting angle is 0 degrees. This will ensure that higher lifts are also safe.

Mounting options:

- ITA Class II, III or IV mounting, depending on clamp size.
- Quick-release mounting hooks.
- Dual-mounting hooks for two different mounting classes.
- Non-standard and special mountings are available on request.

Hydraulic system

Standard delivery includes pressure relief valves for clamping. All hydraulic cylinders are equipped with built-in check valves.

Hydraulic options:

- 4-stage pressure selection valves for easy clamping force control.
- Automatic clamping force control with our Force Matic.

Whatever the purpose - we have the right pad

Bolzoni Auramo has paid special attention in designing and manufacturing contact pads which ensure safe and non-damaging paper roll handling.

All pads have a thin and smooth design with high-friction contact surfaces.

Standard contact pads for all AMC series clamp models are split cast pads.

A wide variety of optional contact pad surfaces is available. Special pad surfaces are available on request.

Full-length unsplit pads are available for most contact pad models. Please contact Bolzoni Auramo for further information.

Standard contact pad options:

- Cast pads, with high friction surface
- Rubber-faced pads, smooth black
- Rubber-faced pads, cross-grooved black
- Rubber-faced pads, cross-grooved white
- Steel-sprayed pads
- Polyurethane-faced pads
- Sandpaper-faced pads

