

Forklift truck service lifts Model 1A-LS

Designed to provide optimum ergonomic workstation



BOLZONI 

Range: 7000 Kg

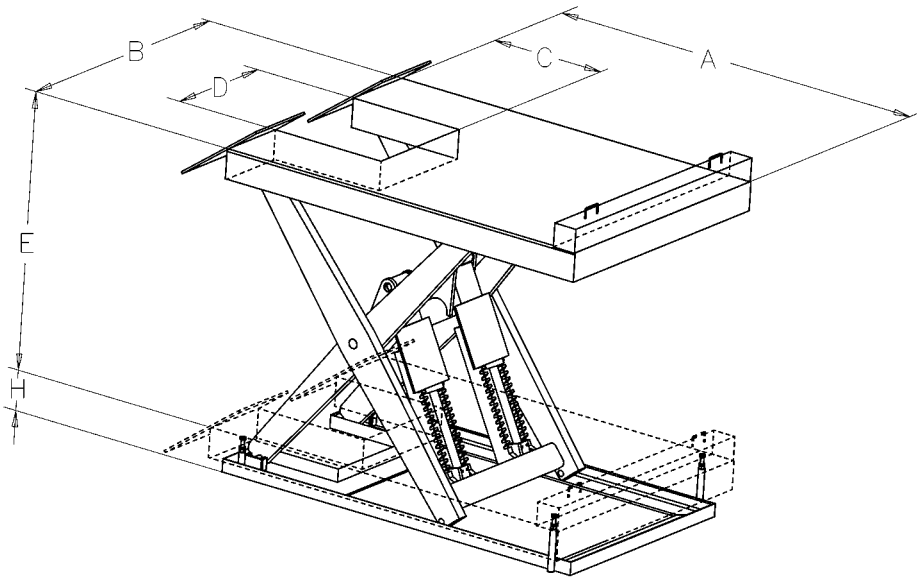

During the maintenance of forklift trucks, the access is complex and often physically painful for the operators.

This lift table model is specially designed to optimize the process of maintenance of forklifts and to provide an optimum ergonomic workstation to improve the working conditions of the operator.

Therefore it represents an investment to provide efficiency and productivity for maintenance and assembly of forklift trucks.

- "U" - shaped platform especially designed for forklift maintenance.
- A rack system ensures the safe stop of the descent. The unlock operation is provided by two pneumatic cylinders.
- Flaps on the front side and safety wheels rear stop system which allows the operator to position the forklift and elevate the table in a safe mode.
- Aluminium safety bar stops the descent of the platform in case of contact with obstructions.

- Single acting hydraulic cylinders equipped with hose safety valve, check valve and drainage.
- Low voltage "Hold-to-run" type control box.
- Maintenance props for safe maintenance operations.
- Removable lifting eye(s) to make easier handling and installation.
- Compliance with the Machinery Directive 2006/42/CE and are manufactured in accordance with UNI EN 1493:2010 safety standards requirements.

Model	Capacity	Stroke	Platform	Collapsed Height	Motor	Cylinder	Lifting time	'U' shape	
	Q kg	E mm	A x B mm	H mm	Kw	n. diam.	sec.	width mm	length/C mm
A1.70.A010	7000	1500	2700 x 1500	450	4,0	2 120	45	650	850

Bolzoni promotes environmental sustainable research and innovation.

For a lower impact on the environment, Bolzoni lift tables are available with biodegradable hydraulic oil on request, and are all provided with high-efficiency electric motors IE3. Lift tables are painted with water based nontoxic solvent free paint.

Bolzoni SpA lift tables facility is certified with the Environment Certificate ISO 14001:2015, since 2006.

BOLZONI S.p.A.

VIA I MAGGIO, 103 - CASONI DI PODENZANO -
29027 PIACENZA (ITALIA)

Tel. +39 0523 55 55 11 - Fax +39 0523 52 40 87

www.bolzonigroup.com - sales@bolzonigroup.com

BOLZONI 